

The University of Oklahoma  
2007 ASCE Concrete Canoe Team  
Presents

# *CENTENNIAL*



## Innovative Features

- Shrinkage Compensating Concrete
- High Composite Fiber Dosage
- Internal Curing
- Mechanically Activated Fly Ash

**Table of Contents**

Executive Summary.....	i	Design Drawings and Bill of Materials	
Hull Design.....	1	Mold.....	9
Analysis.....	2	Hull.....	10
Development and Testing.....	3	Appendix A - References.....	A-1
Construction and Project Management..	5	Appendix B - Mixture Proportions.....	B-1
Organization Chart.....	7	Appendix C - Gradation Curves	
Project Schedule.....	8	and Tables.....	C-1

**Executive Summary**

The University of Oklahoma was founded in 1890 as Norman Territorial University. After the admission of Oklahoma to the union in 1907, the school was renamed The University of Oklahoma. The year 2007 celebrates both the *centennial* of the state of Oklahoma and the university as we know it today. The student body of the Norman campus has grown to over 23,000 undergraduate and 3,000 graduate students. Currently, 196 undergraduate students are enrolled in the School of Civil Engineering and Environmental Science. Forty-four of these students are members of ASCE. Our team consists of 12 students and a faculty advisor. The University of Oklahoma has proudly participated in twelve Mid-Continent regional competitions, winning four, and has attended five national competitions. Our highest national placement was fifth in 2003.

This year’s entry, **CENTENNIAL**, is a testament to what it means to be an Oklahoma Sooner. A Sooner symbolizes the progressive way of thinking imbedded in the foundation of our great state. Progress is the theme that culminated in **CENTENNIAL**. All aspects of the design/build process exhibited a major progression from previous canoes. By implementing innovative changes with previously proven methods, the team was able to take **CENTENNIAL** to the highest level in OU’s history.

Changes for 2007 began with a new hull design. Flared walls, a shallow-V bottom, and hard chines replaced the tumblehome and elliptical bottom used by our team for the past four years. This new design was selected to simplify construction, increase stability, and improve tracking. A thorough structural analysis, using both hand calculations and finite element modeling, was completed to ensure that our new design would survive the rigors of the competition. Construction of the mold was optimized by using a 3-axis Computer Numerical Control (CNC) mill. This decreased mold construction time by 80% from last year, allowing more time to be focused on the testing of 132 mixes, the largest mix design process in OU history. Innovative features of the **CENTENNIAL** mix design include: shrinkage compensating cement, high composite fiber dosage, internal curing, and mechanically activated fly ash. This system created a state-of-the-art shrinkage compensated concrete that increased strength and eliminated all shrinkage during curing. The University of Oklahoma student chapter of ASCE is proud to present **CENTENNIAL** to the 2007 ASCE National Concrete Canoe Competition.

**CENTENNIAL Quick Facts**

Canoe Specifications		Concrete Properties and Reinforcement	
Colors	Crimson, Cream, and Black	Unit Weight	58.5 pcf
Length	19.75 ft	Compressive Strength	2420 psi
Width	31 in	Flexural Strength	490 psi
Depth	13 in	Tensile Strength	210 psi
Average Thickness	0.5 in	Fiberglass Mesh Reinforcement	4.3 oz/yd <sup>2</sup>
Weight	215 lbs	1/16” Wire Rope (Post-Tensioned)	260 ksi

## Hull Design

- Goals:** 1) Design a new hull that improves stability and tracking without significant loss in speed.  
2) Create an effective design with emphasis given to efficiency during concrete placement.

The hull design of *CENTENNIAL* is a progression from the design used in past years. The focus in previous designs was to maximize speed potential. Speed potential is dependent on the force the paddlers are able to create. After discussion with experienced paddlers and alumni, it was determined that previous canoes were not reaching their peak speed because too much effort was being used to keep the canoe upright and on course. The casting team from the previous year was also consulted about changes in hull shape to simplify placement. With this information, the hull design team chose a radically new design that maximized propulsion paddling effort and constructability.

After extensive research, the team decided that a cross section featuring flared gunwales, a shallow V bottom, and hard chines would accomplish all goals. The cross section design changes are presented in Figure 1. The profile of *CENTENNIAL* features 2.5" of rocker in the bow and 2" of rocker in the stern. Restrictions placed on the dimensions of the canoe required a decrease in length of the canoe to 19'-9". *CENTENNIAL* maintained the asymmetric hull philosophy used in previous designs which decreases bow wave resistance at the most sensitive region of the canoe by decreasing the entry angle. The maximum width of 31" is located 10'-10" from the bow or 55% of the total length.

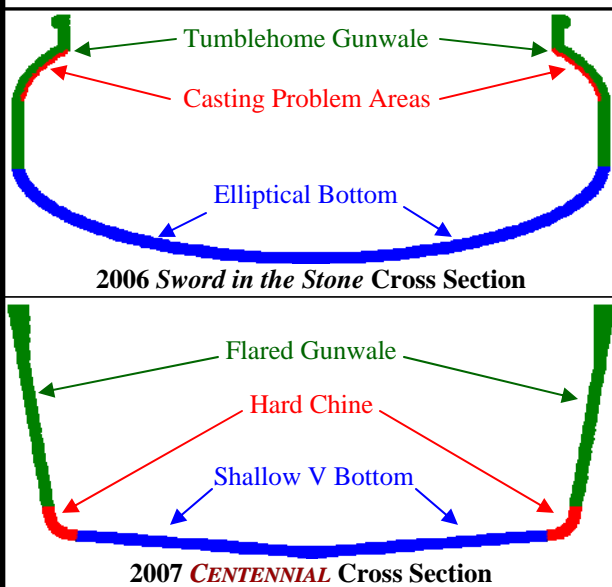

**Figure 1:** Comparison of Hull Cross Sections from 2006 (*Sword in the Stone*) to 2007 (*Centennial*).

Flared walls were the logical choice to efficiently stabilize the canoe and simplify construction. The increase in waterline width with decreasing free-board provides greater stability as more weight is placed in the canoe. Similarly, a lighter canoe will have a higher length/beam ratio. Length/beam ratio is the length at the waterline divided by the beam at waterline; the higher the ratio the higher the speed potential due to decreased wave resistance (Stejskal 2006). A flared wall increases the potential speed for the men's and women's sprint races, when stability is not a critical issue. Conversely, stability is increased for the endurance and coed sprint races, while maintaining equal speed potential to that of the previous tumblehome design. The flared wall also simplified construction by eliminating the need to place concrete in the overhead position required by the tumblehome geometry as shown in Figure 1.

The shallow V bottom acts as a keel line by directing water along the length of the canoe rather than allowing the free flow of water laterally (Moore 2000). Additionally, decreasing the bow rocker from three inches to two and a half inches increases the tracking ability of the canoe (Evergreen 2005). A problem with the shallow V is that the restriction of lateral water movement hampers turning. This was addressed by adding a hard chine at the transition from the bottom to the gunwale. The hard chine acts as a curved secondary keel line when heeling, which helps to turn the canoe (Lockwood 2006).

After the design features were selected, the location of the hard chine was varied to determine its ideal location. The team used a hydrostatic modeling program, RhinoStatics, to find relevant naval coefficients. These coefficients were then entered into a drag calculating program, KAPERS (Winters 2004). It was found that the best location for the chine was 12" below and 2" inboard from the top of the gunwale. With the hull design complete, the progressive design of *CENTENNIAL* was taking shape.

## Analysis

- Goals:** 1) Determine critical stresses in compression, tension, and flexure.  
 2) Use a better representation of buoyant force during analysis than previous years.

The structural analysis team was charged with accurately determining the minimum compressive, tensile, and flexural requirements for **CENTENNIAL**. To progress from prior years the team wanted a more representative model of the buoyant force supporting the hull so an accurate prediction of the maximum moment could be made.

A total of seven loading cases were considered to simulate the various forces applied throughout the competition, including the five different races, weigh-in, and the aesthetic display. The weight of a male paddler was assumed to be 180 lbs and a female paddler was assumed to be 125 lbs. The buoyant force was computed by first taking a horizontal slice through the canoe at the surface of the water. The force was then distributed along the length of the canoe proportional to the width, as shown in Figure 2. The self-weight of the canoe was subtracted from the buoyant force during analysis. Once all of the loads were determined, they were applied to a one-dimensional beam model. The maximum moment was calculated and the minimum required tensile and compressive strengths were determined. The fiberglass mesh and wire rope reinforcement were neglected during the analysis because they are meant to provide secondary reinforcement and rigidity. With this assumption, all minimum required concrete strengths are conservative.

The initial loading case calculations were computed by hand, but most calculations were done in a Microsoft Excel spreadsheet. This spreadsheet allowed the team to input loads at different points in **CENTENNIAL** and have all moments calculated instantaneously. From this analysis, it was determined that the worst case scenario for bending moment is -7170 lb-in occurring near mid-canoe during the co-ed sprint race. An illustration of the critical loading parameters and the related moment diagram is shown in Figure 2. The team analyzed a cross section of the canoe at the location of the maximum moment to determine the required strengths. The minimum required strengths during bending were found to be 120 psi in compression and 190 psi in tension.

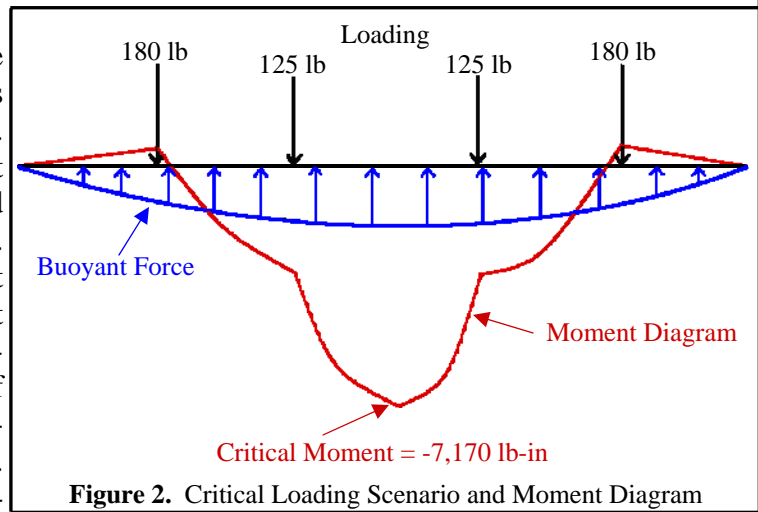

**Figure 2.** Critical Loading Scenario and Moment Diagram

The bottom of **CENTENNIAL** was simulated by a finite element model, using a plate measuring 15"x15"x0.5" with all degrees of freedom along the edges restricted. Two 2"x2" squares were spaced 6" apart and loaded with 144 pounds each. This load is half of the male weight multiplied by a live loading factor of 1.6 to compensate for shifting of weight during paddling (ACI 2005). The minimum required flexural strength was calculated to be 440 psi and the minimum required shear strength was calculated to be 72 lbs. Concrete shear strength, per ACI 318, is dependant on compressive strength, which changed the minimum required compressive strength to 1300 psi.

The analysis conclusions for the minimum required material strengths are presented in Table 1. With the required concrete strengths established, the development team could now select the structural concrete mixtures for **CENTENNIAL**.

Table 1. Analysis Conclusions		
Material	Property	Analysis Strength Requirement (psi)
Concrete	Compression	1300
	Tension	190
	Flexure	440
Mesh	Tension	0
Wire Rope	Tension	0

## Development and Testing

- Goals:** 1) Investigate new binders, aggregates, and fibers for viability in mix.  
2) Develop concrete with required strength, workability, buoyancy, and aesthetic appeal.

Prior successes combined with new techniques led to the innovative mix design for **CENTENNIAL**. The development team wanted innovative mixes that would be buoyant, experience no shrinkage, have excellent workability with low slump, and provide integral full-depth color. During the mix development, five different types of aggregates were tested, along with integral coloring. Several innovations, including shrinkage compensating cement, high composite fiber dosage, internal curing, and mechanically activated fly ash were used to progress the team's design from prior years. Concrete strengths were found using compression (ASTM 2007a), splitting tensile (ASTM 2007b), and modulus of rupture (ASTM 2007c) tests at 14 and 28 days. The final mix was selected after 132 trial mixes had been batched and tested: the most extensive light weight concrete development process in OU history.

The aggregate type and proportions were chosen early in the process. Several aggregates, including perlite, glass beads, glass microspheres, expanded shale, and styrofoam were selected for testing due to their availability and low unit weights. Perlite and styrofoam were discarded due to unpredictable unit weights and poor strength characteristics. The remaining aggregates were used to produce a gradation within the fine aggregate limits of ASTM C33. The expanded shale was soaked overnight and patted dry before casting to create saturated-surface-dry conditions. This allowed the shale to internally cure the concrete, reducing the drying shrinkage (Bentz 2006) and permeability (Shattaf et al. 2001).

Binder option 3 produced higher mix strengths at lower unit weights and became the focus for further testing. The initial binder proportion selected was 60% Portland cement, 15% fly ash, and 25% slag cement. Slag cement was chosen because it produces low permeability concrete when substituted for Portland cement (SCA 2002). The fly ash, selected from prior success, was mechanically activated to remove surface impurities and produce a larger surface reaction area (Kiamenesh and Ramseyer 2006). Several binder weights (600-800 lb/yd<sup>3</sup>) were tested to determine which option would achieve the desired strength and unit weight. The binder weight of the **CENTENNIAL** mix is 707 lb/yd<sup>3</sup>.

In the spirit of innovation, the **CENTENNIAL** team created a shrinkage compensated concrete. Shrinkage compensated concretes use Type G or K cement additive with standard Portland cement binder (ACI 1998). The team chose to use an ASTM C845 Type-K cement, which is expansive to compensate for the normal shrinkage Portland cements experience. The Type-K cement was tested in proportions varying from 0-15% of the binder weight. Shrinkage of these mixes was measured for 42 days to find the ideal range of expansion. This expansion induces tension in the reinforcement and compression in the concrete. During drying any tendency to shrink merely relieves the expansive strains (CTS 2005). Ten percent of the binder weight was selected as the amount of Type-K cement for the mix.

When Type-K cement is used, it is imperative that the early expansion of the cement be restrained. Very short (1/4") state-of-the-art composite fibers were used to provide restraint to the early expansion of the mix. The fibers tested have an elastic modulus (6 ksi) similar to concrete and improved surface characteristics. These improvements allow the fiber to provide strength benefits prior to cracking by forming a truly composite material. Lab tests have shown a 40% increase in flexural strength with the addition of over 100 lb/yd<sup>3</sup> (Ed Rice, personal communication, 10/31/2006). The **CENTENNIAL** development team sought to find a balance between the workability and strength of the structural mixes. The team tested fiber addition rates ranging from 0-60 lb/yd<sup>3</sup>. The best results were found at 36 lb/yd<sup>3</sup>, which provided a more than 20% increase in flexural strength while sustaining the desired workability.

A time-zero shrinkage test was run to assess the effect that our selected dosages of fiber and Type-K cement had on the shrinkage (Ramseyer and Kao 2005). Four mixes were tested; one containing no fiber, one with no shrinkage compensating cement, one containing neither component, and one with

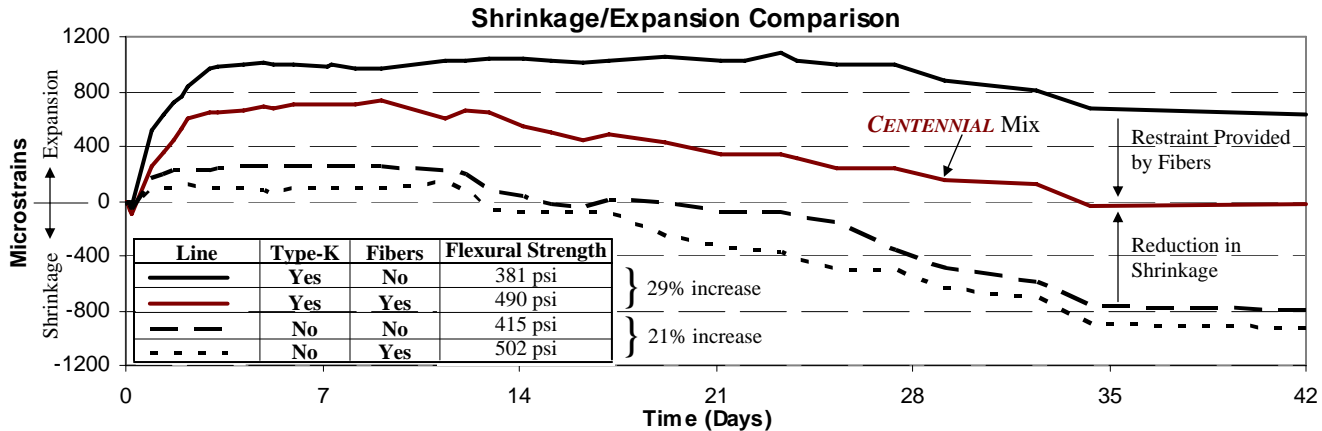

Figure 3. Shrinkage and Strength Comparisons with Additions of Fibers and Type-K Cement.

both components. The results are shown in Figure 3 along with the flexural strengths of the mixes. These results show a more than 20% increase in flexural strength with 36 lbs/yd<sup>3</sup> of fiber and a reduction in final shrinkage from 800 to 20 microstrains with 10% of the binder being Type-K cement.

From past successes, the team selected a 4.3 oz/yd<sup>2</sup> fiberglass mesh as reinforcement. The mesh runs throughout the midpoint of the hull of *CENTENNIAL* and has a percent open area of 63% to provide secondary reinforcement. While the concrete achieved a tensile strength large enough to meet design load conditions, the development team chose to use a post-tensioned wire at the top of the gunwale to improve the stiffness of *CENTENNIAL*. A 1/16" wire rope was selected for its large bonding area and high elastic modulus to provide the stiffness needed to meet all serviceability requirements.

Admixture selection was based on prior experiences. The percent of latex was based on a ratio of the solid latex per cementitious material in the mix. Latex quantities between 10% and 25% were tested. Targeting optimal flexural strength resulted in the selection of a 15% dosage rate. The development team wanted to design for an air content of 10% to exceed the 6% required by the rules. Since air entrainment is sensitive to environmental conditions, the extra targeted 4% would ensure a compliant gravimetric air content on casting day. The recommended dosage for the selected air entrainer is 1-3 fl oz/cwt for typical air entrainment of 4-8%, so this dosage was doubled to meet our specifications. During testing, the mix team noticed that even after adding double the manufacturer's recommended dosage, they were getting unexpectedly low air contents. After speaking with a representative from the manufacturer, the team determined that the air entrainment was interacting with the latex. This problem was solved by mixing the concrete without air entrainment for one minute. Then air entrainment was added and the concrete mixed for two more minutes. This process allowed the team to achieve the targeted 10% air content.

To make *CENTENNIAL* aesthetically pleasing, the team utilized mineral pigments and white cement. The team wanted a canoe featuring a crimson exterior and cream interior with black inlays celebrating the history of the university and the state. Pigments were added to Portland cement to create the black and crimson colors, while white Portland cement was used to make the cream color. The white cement was substituted with no significant effect on the strength or shrinkage properties of the concrete. A finishing mixture was created to fill in any voids left after sanding and to produce a more vibrant color. These mixes were modified by removing the fibers and increasing pigment dosage.

The development team for *CENTENNIAL* was successful in meeting all its goals. The innovative mix design produced a shrinkage compensated concrete that met all strength requirements as shown in Table 2.

Table 2. Material Strengths and Analysis Conclusions Comparison

Material	Property	Analysis Strength Requirement (psi)	Material Strength Provided (psi)
Concrete	Compression	1300	2420
	Tension	190	210
	Flexure	440	490
Mesh	Tension	0	127 (ksi)
Wire Rope	Tension	0	260 (ksi)

## Construction

- Goals:** 1) Decrease mold construction time and cost without sacrificing quality.  
2) Generate an efficient casting procedure to ensure uniformity and eliminate confusion.

Mold construction for *CENTENNIAL* progressed from prior years by using CNC milling to cut the foam directly from our computer models. This reduced the number of hours spent creating the mold by 80% from last year. By changing to a male mold from previous female molds, the team was able to reduce the difficulty in construction and finishing of *CENTENNIAL*.

The mold was milled in four, five-foot long sections. The pieces were then assembled by connecting the sections using 1" electrical conduit pipe, placed into the same holes that were used to support the mold pieces during CNC milling. To hold the pieces together, a thin layer of foam sealant was applied between the sections and allowed to set. This technique was also used to attach the assembled mold to a rigid platform. The platform supplies a rigid support which allows higher accuracy in construction and ease in transporting the mold. It was necessary to strengthen the mold surface to reduce the risk of incidental localized mold deformation. The likelihood of local deformation was a result of the low impact resistance of the foam material used to make the mold. After testing many methods, the team chose to strengthen the mold by applying a layer of fiberglass mesh and several thin coats of fiberglass resin. This gave the mold sufficient strength as well as an even surface which provided an easy release and smooth finish for the inside of *CENTENNIAL*.

To create the inlays in *CENTENNIAL*, the aesthetics team chose a procedure using cutouts made from rubber sheeting that were attached to the mold in their desired locations using rubber cement and nails. The layer of fiberglass reinforcement was sewn together and cut to fit the mold. The mold was prepared for concrete casting by coating it with several layers of wax to act as a releasing agent. Twenty-five 1" wide rubber strips were cut from the same material as the inlays to be used as 1/4" thickness controls. The strips were then laid across the width of the canoe at 10" intervals along the length of the canoe.

An instructional video detailing the casting procedure was created and shown to the team for the first time in school history. The video allowed the team to get a visual picture of how casting should be completed. As a result, there was much less confusion during the actual casting process, ensuring that *CENTENNIAL* would be a more predictable and higher quality product.

For casting, concrete was hand applied to the mold. First, a layer of the *Cream* structural mixture was placed on the mold between our thickness gauge strips, and around the inlay cutouts. The gauge strips were then removed and their voids filled to the level of the surrounding concrete mixture. The prepared reinforcement layer, exterior thickness gauge strips, and exterior inlay cutout were laid out over the surface of the first layer of concrete. Next, a layer of our *Crimson* structural mixture was applied over the *Cream* layer using the same technique. The thickness gauges were again removed and filled in with the *Crimson* structural mixture. The exterior surface was smoothed out using rolling pins over a layer of wax paper. A tent was built around the finished canoe to control the humidity until initial set was achieved. After 24 hours, wet burlap sacks were laid over the surface of the canoe as suggested by the shrinkage compensating cement manufacturer. The burlap sacks were kept constantly moist until their removal at 14 days. The canoe was then allowed to dry-cure for another 14 days.

After de-molding *CENTENNIAL*, the production team constructed flotation tanks using spray foam. The tanks were then covered in a 1/2" layer of *Cream* structural concrete. The inlay cutouts were removed, taped off, and filled with *Black* inlay concrete. A groove was cut along the top of the gunwale and the wire rope was tensioned to 50 lbs (stress of 16,000 psi) and cast in concrete. *CENTENNIAL* was then sanded, given an application of finishing concrete, and fine sanded to the desired smoothness. Finally, two coats of silane based sealer were applied according to the manufacturer's recommendations.

## Project Management

- Goals:** 1) Establish a reliable method of communication between all team members.  
 2) Emphasize safety and quality control during training of new members.

The Oklahoma concrete canoe team is strictly a voluntary organization. This resulted in a fluctuation in team member involvement throughout the course of the project. This fluctuation required an efficient communication system to get new members up to speed and keep all members informed. A three person leadership team, formed by a project manager, development engineer, and production engineer, set the foundation for the efficient completion of **CENTENNIAL**. These individuals were chosen based on their expertise and dependability. The development engineer oversaw all activities related to hull design, mix development, and structural analysis. The production engineer supervised all construction related tasks, including the practice canoe, mold, concrete placement, display, and finishing. Both engineers reported directly to the project manager who was responsible for fundraising, recruiting, communication, quality control, and implementation of the safety program. A flow chart of the project organization structure is presented on page 7. This management system was chosen for its effectiveness in communication and mentoring of new members. The successful transfer of knowledge to new members assured a quality product, no matter which team member completed the work.

A schedule was made prior to the start of the project to ensure timely completion of all required activities. Several major milestones were identified from past experience and the critical path was based on the completion of these tasks (Table 3). Within the critical tasks were several supplemental tasks that could be distributed among team members to aid in the timely completion of the main task.

A detailed project schedule with supplemental tasks is presented on page 8. Thirty students contributed 2,000 man-hours during the completion of this project. A summary of the man-hours worked is presented in Figure 4. The 108 hours spent on construction of the mold is an 80% decrease from last year.

**Table 3: Project Milestones**

Milestone Activity	Scheduled Completion	Actual Completion	Variance Explanation
Hull Design	October 13	October 6	Summer Research
Structural Analysis	November 17	December 22	Multiple Methods
Mix Design	January 27	February 7	Pigment Testing
Mold Construction	January 30	January 26	CNC Milling
Casting	February 3	February 10	Mix Selection Delay

The completion of **CENTENNIAL** required a significant amount of money. These costs were covered by both industry and alumni donations of funds and materials. The team asked for material donations early in the year so that work could begin on the mix design. All of the materials tested had free sample availability. Monetary donations were requested in November when an accurate estimation of costs was obtained. The majority of this money was spent on construction, which required materials that were not donated, including fiberglass resin, urethane foam, and sanding equipment. The construction of **CENTENNIAL** finished under budget due to better concrete placement, which decreased sandpaper use from past years. This resulted in additional money that was used for the aesthetics display, which had previously lacked funding.

Safety is every team member's responsibility. Strict safety measures were taken to ensure zero possibility of injury. Masks, gloves, eye protection, and proper ventilation were used in accordance with material safety data sheets and OU policies. Two thousand injury-free hours show **CENTENNIAL** to be a true success.

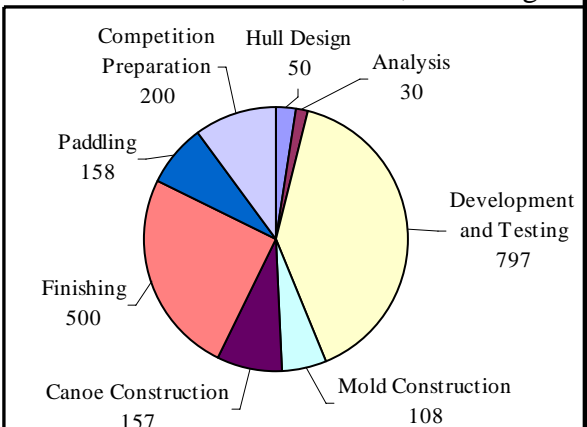

**Figure 4.** Summary of Man-hours worked.

# Organization Chart

**Project Manager**  
*Russell Buhler*  
 Responsible for fundraising, recruiting, communication, quality control, and implementation of the safety program



**Development Engineer**  
*Chris Davis*  
 Supervised all activities related to hull design, mix development, and structural analysis



**Production Engineer**  
*Marty Farris*  
 Supervised all construction related tasks including the mold, casting, final product display, and finishing



**Engineer in Training**



*Promise Janning*  
 Served as apprentice to Development Engineer

**Fundraising**  
*Brent Chancellor*

**Recruiting**  
*Lauren Parrish*

**Design Paper**  
*Chris Davis*  
*Marty Farris*  
*Katie Daugherty*  
*Michaela Campbell*  
*Casey Price*  
*Brock Lindsey*  
*Jacque Martin*  
*Brett Moran*

**Paddling**  
*Russell Buhler*  
*Lauren Parrish*  
*Marty Farris*  
*Jacque Martin*  
*Chris Davis*  
*Michaela Campbell*  
*Promise Janning*  
*Mark Emde*

**Engineer in Training**



*Michaela Campbell*  
 Served as apprentice to Production Engineer

**Hull Design**  
*Russell Buhler*

**Structural Analysis**  
*Marty Farris*

**Prototype**  
*Ted Huynh*  
*Michaela Campbell*

**Testing**  
*Brock Lindsey*  
*Marty Farris*

**Oral Presentation**  
*Russell Buhler*  
*Marty Farris*  
*Chris Davis*  
*Katie Daugherty*  
*Lauren Parrish*

**Engineer's Notebook**  
*Katie Daugherty*

**Cutaway**  
*Brock Lindsey*  
*Mark Emde*

**Display Stands**  
*Brent Chancellor*

**Display Table**  
*Katie Daugherty*  
*Jacque Martin*

**Mold Preparation**  
*Katie Daugherty*  
*Ted Huynh*

**Humidity Tent**  
*Brandon Birch*  
*Mark Emde*

**Instructional Video**  
*Promise Janning*

**Placement**  
*Entire Team*

**Finishing**  
*Entire Team*

**Mix Design**  
*Promise Janning*  
*Michaela Campbell*  
*Casey Price*

**Reinforcement Design**  
*Russell Buhler*

**Testing**  
*Brock Lindsey*  
*Brett Moran*

**Mix Development Team**

**Hull Development Team**

**Technical Communication Team**

**Aesthetic Display Team**

**Production Team**

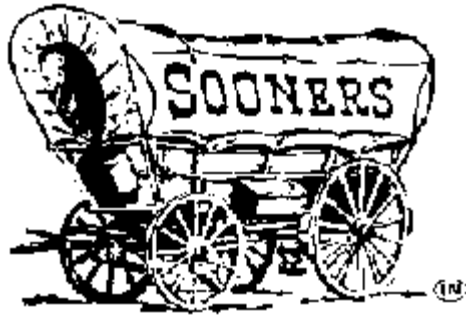

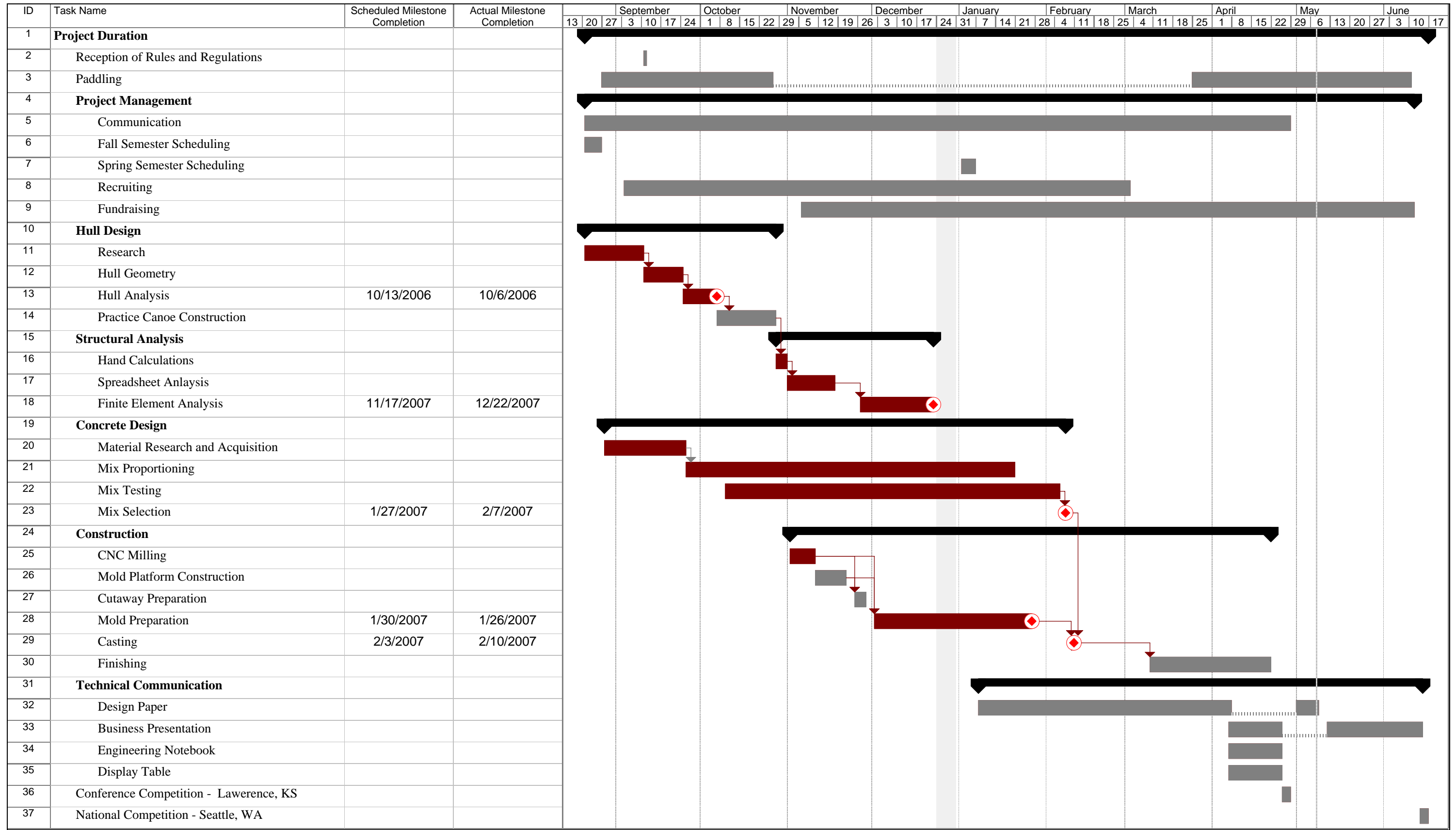

Project: *Centennial*      Summary      [Critical Path Task]      [Task]      [Milestone]      [Split]

The University of Oklahoma  
ASCE Student Chapter

Bill of Materials

NO.	Description	Quantity	Unit
1	Urethane Foam	105	ft <sup>3</sup>
2	Foam Glue	0.05	ft <sup>3</sup>
3	1" Electrical Conduit	10	LF
4	Fiberglass Mesh	72	ft <sup>2</sup>
5	Fiberglass Resin	3	gal
6	Car Wax	12	oz
7	Plastic Filler	0.01	ft <sup>3</sup>
8	1/4" Tack Nails	100	EA

General Notes:

- Sections A-A, B-B, and C-C are located at the junctions of the four five-foot pieces of the mold.
- Urethane foam (1) quantity based on pre-cut volume.
- Plastic filler (7) used to repair imperfections created in the foam during transportation.
- Tack nails (8) used to hold fiberglass mesh (4) in place during application of resin (5).

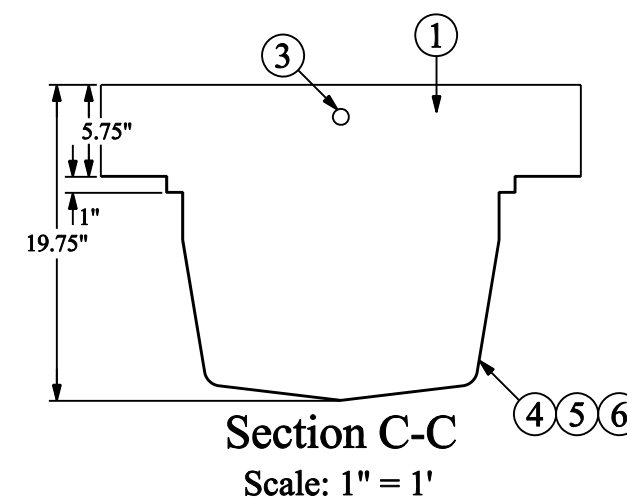
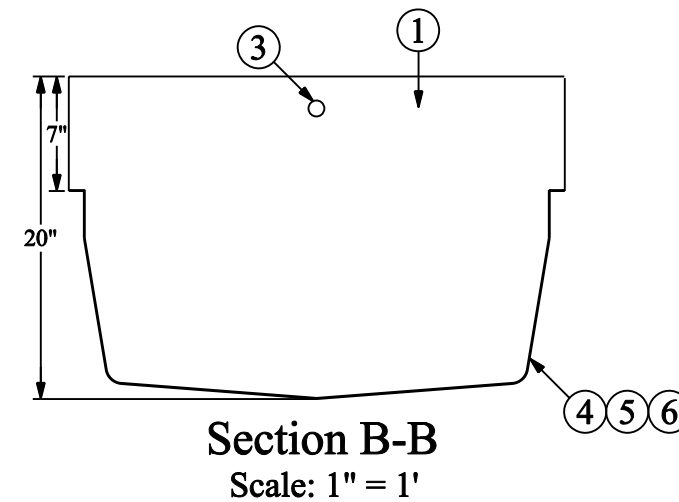
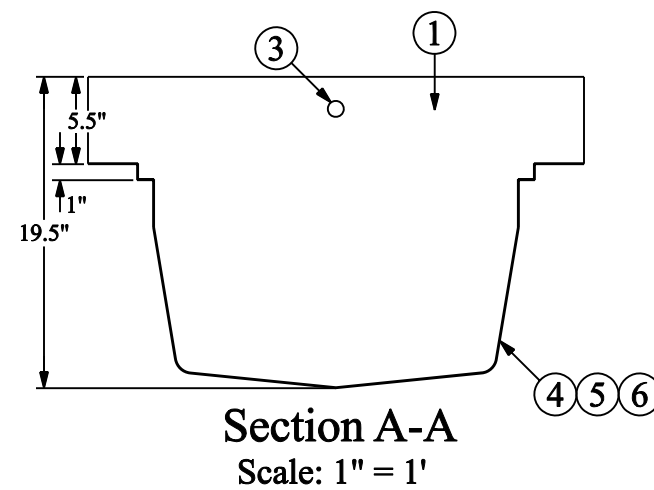
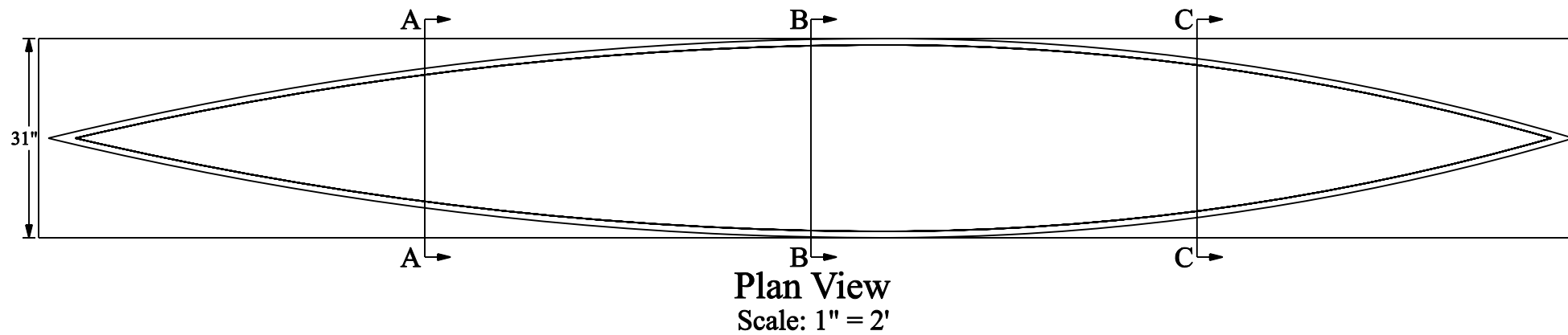
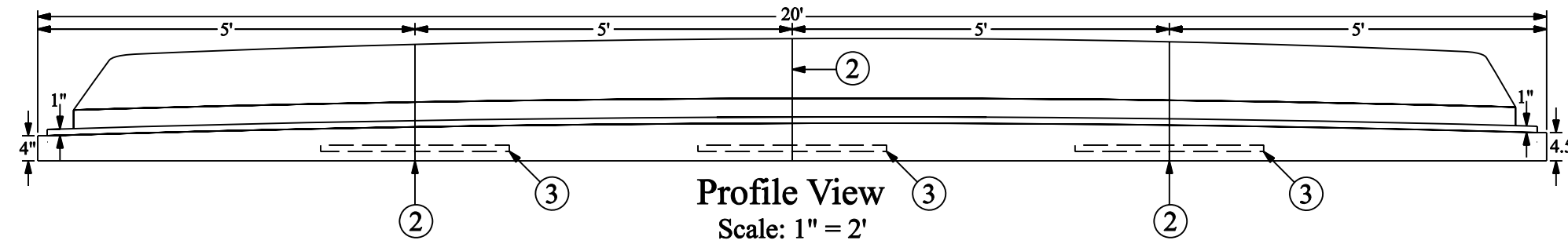

Engineer: Russell Buhler

Drawn By: Russell Buhler

Date: 03-18-2007

Checked By: Chris Ramseyer

Date: 03-29-2007

Project Name: *Centennial*

Drawing Name: Mold Design

Sheet Number: 9

The University of Oklahoma  
ASCE Student Chapter

Bill of Materials

NO.	Description	Quantity	Unit
1	"Crimson" Structural Concrete	1.5	ft <sup>3</sup>
2	"Cream" Structural Concrete	1.5	ft <sup>3</sup>
3	"Black" Inlay Concrete	0.2	ft <sup>3</sup>
4	Fiberglass Mesh Reinforcement	72	ft <sup>2</sup>
5	1/16" Wire Rope	45	LF
6	Spray Foam	2	ft <sup>3</sup>
7	"Crimson" Finishing Concrete	0.1	ft <sup>3</sup>
8	"Cream" Finishing Concrete	0.1	ft <sup>3</sup>
9	4.5" Decals (School Name)	2	EA
10	3.5" Decals (Canoe Name)	2	EA
11	Coat of Sealer	2	EA

General Notes:

- Wire rope (5) was added and tensioned 28 days after initial casting in 3/16" deep trench cut along the length of the canoe gunwale
- Fiberglass mesh (4) is located between two equal layers of "Crimson" (1) and "Cream" (2) concrete
- Flotation foam (6) and cover (2) added after removal from mold
- All concrete volumes representative of amount that was cast, not final amount after finishing



Engineer: Russell Buhler

Drawn By: Russell Buhler

Date: 03-18-2007

Checked By: Chris Ramseyer

Date: 03-29-2007

Project Name: *Centennial*

Drawing Name: Hull Design

Sheet Number: 10

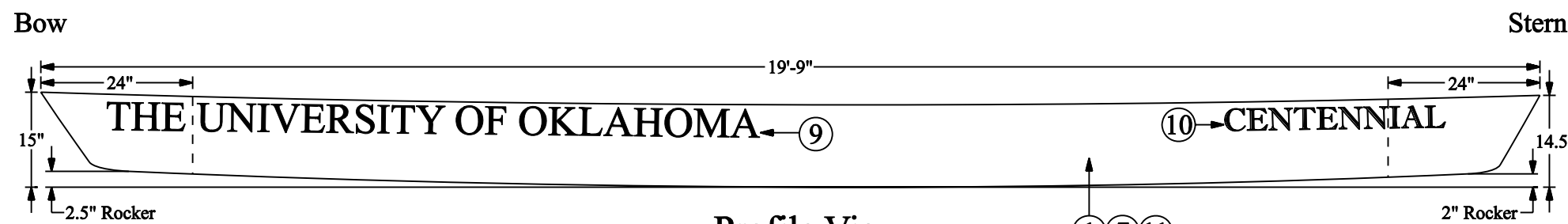

Profile View  
Scale: 1" = 2'

1 7 11

Note: Section widths are located at 4-foot intervals from the bow.

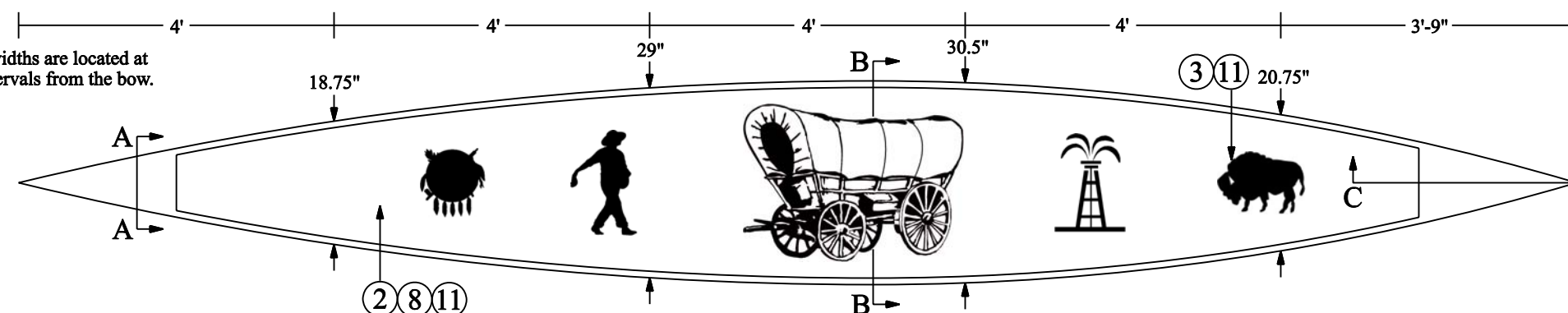

Plan View  
Scale: 1" = 2'

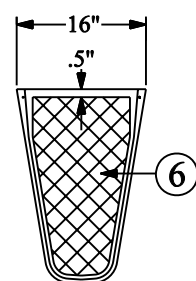

Section A-A  
Located 18" from bow  
Scale: 1" = 1'

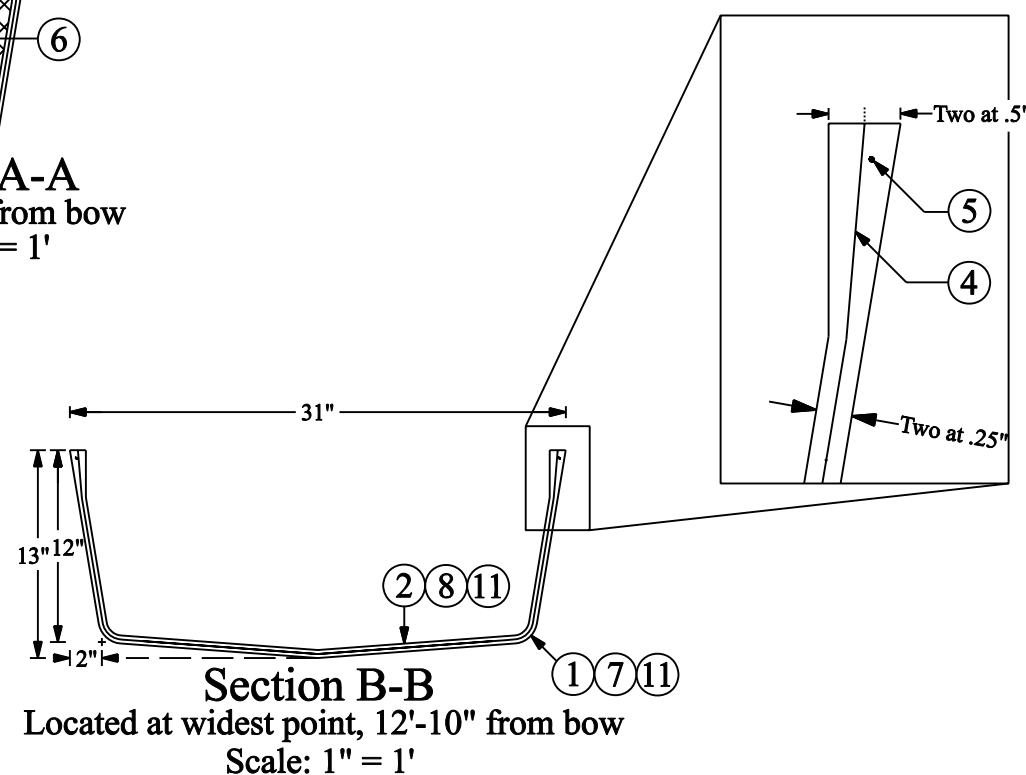

Section B-B

Located at widest point, 12'-10" from bow

Scale: 1" = 1'

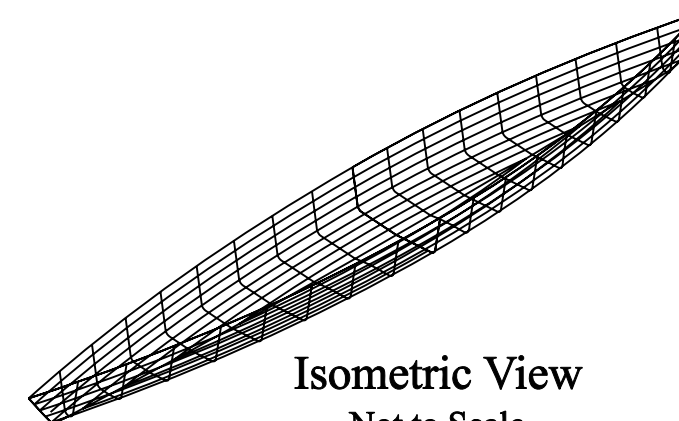

Isometric View  
Not to Scale

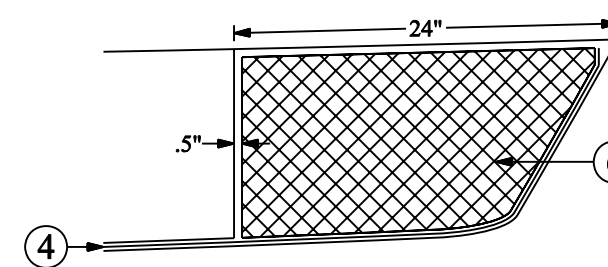

Section C-C

Scale: 1" = 1'

## Appendix A - References

- ACI (1998). "Standard Practice for Use of Shrinkage Compensating Concrete." *ACI 223-98*. American Concrete Institute, Farmington Hills, MI.
- ACI (2005). "Building Code Requirements for Structural Concrete and Commentary." *ACI 318-05*. American Concrete Institute, Farmington Hills, MI.
- ASCE (2006). *2007 American Society of Civil Engineers National Concrete Canoe Competition - Rules and Regulations*. American Society of Civil Engineers, Reston, VA
- ASTM (2007a). "Standard Test Method for Compressive Strength of Cylindrical Specimens." *ASTM C39/C39M-05e1*. American Society of Testing and Materials. West Conshohocken, PA.
- ASTM (2007b). "Standard Test Method for Splitting Tensile Strength of Cylindrical Concrete Specimens." *ASTM C496/C496M-04e1*. American Society of Testing and Materials. West Conshohocken, PA.
- ASTM (2007c). "Standard Test Method for Flexural Strength of Concrete (Using Simple Beam with Third Point Loading)." *ASTM C78-02*. American Society of Testing and Materials. West Conshohocken, PA.
- ASTM (2007d). "Standard Specification for Concrete Aggregates." *ASTM C33-03*. American Society of Testing and Materials. West Conshohocken, PA.
- ASTM (2007e). "Standard Specification for Expansive Hydraulic Cement." *ASTM C845-04*. American Society of Testing and Materials. West Conshohocken, PA.
- Bentz, D.P. (2006). "Internal Curing of High-Performance Blended Cement Mortars: Autogenous Deformation and Compressive Strength Development." National Institute of Science & Technology. ACI Convention. November 5-9, 2006. Denver, CO.
- CTS Cement (2005). "CTS - System-K Data Sheet." <[http://www.ctscement.com/SystemK\\_data.asp](http://www.ctscement.com/SystemK_data.asp)> December 10, 2006.
- Evergreen Canoe Co. (2005). "Canoe Designs." <[http://www.evergreencanoe.com/canoe\\_design.html](http://www.evergreencanoe.com/canoe_design.html)> July 20, 2006.
- Kiamanesh, R. and Ramseyer, C.C. (2006). "Mechanically Activated Fly Ash for Blended Cement." Fears Structural Engineering Laboratory, University of Oklahoma. September 2006
- Lockwood, J. (2006). "Hard Chine versus Multi-Chine Kayaks." <<http://www.pygmyboats.com/Comparison.htm>>. July 18, 2006.
- Moores, T. (2000). *Canoeecraft: An Illustrated Guide to Fine Woodstrip Construction*. Firefly Books.
- Ramseyer, C.C. and Kao, J.T. (2005), "A Study of Shrinkage in Concrete from the Time of Casting." *American Concrete Institute, Annual Spring Convention*, New York, NY, April 2005.

**Appendix A - References**

- SCA (2002). *Reducing Permeability*. <[http://slagcement.org/image/123800\\_c\\_sU128801\\_s\\_i185500/No6\\_Reducing\\_Permeability.pdf](http://slagcement.org/image/123800_c_sU128801_s_i185500/No6_Reducing_Permeability.pdf)>. Slag Cement Association. Sugar Land, TX. August 13, 2006.
- Shattaf, N.R., Alshamsi, A.M., and Swamy, R.N.(2001) "Curing/Environment Effect on Pore Structure of Blended Cement Concrete," *Journal of Materials in Civil Engineering*, **13**(5), 380-388, 2001.
- Stejskal, V. (2006). "Kayak Design Terms & Hydrostatics." <<http://oneoceankayaks.com/smhydro/hydro.htm#lbratio>>. July 14, 2006.
- Winters, J. (2004). "The Shape of the Canoe." <<http://boatbuilding.com/article.php/ShapeoftheCanoe#Design%20Criteria%20for%20New%20Canoe>>



## Appendix B - Mixture Proportions

Mixture: Cream Structural Mixture		SSD Proportions as Designed		Actual Batched Proportions		SSD Yielded Proportions		
Batch Size (ft <sup>3</sup> ): 0.3		Amount (lb/yd <sup>3</sup> )	Volume (ft <sup>3</sup> )	Amount (lb)	Volume (ft <sup>3</sup> )	Amount (lb/yd <sup>3</sup> )	Volume (ft <sup>3</sup> )	
<b>Cementitious Materials</b>		Specific* Gravity						
1. White Portland Cement Type: I		3.15	353.50	1.798	3.93	0.020	345.18	1.756
2. Class C Fly Ash		2.58	106.05	0.659	1.18	0.007	103.55	0.643
3. Slag Cement		3.00	176.75	0.944	1.96	0.010	172.59	0.922
4. CTS Type-K Cement		3.10	70.70	0.365	0.79	0.004	69.04	0.357
Total of All Cementitious Materials			707.00	3.767	7.86	0.042	690.36	3.678
<b>Fibers</b>								
1. CTS K-Fiber™		2.7	36.00	0.214	0.40	0.002	35.15	0.209
<b>Aggregates</b>								
1. Buildex Expanded Shale - <i>Marquette</i>		1.6	43.46	0.435	0.48	0.005	42.44	0.425
Absorption: 10 % Batched Moisture Content: 10 %								
2. Poraver (1-2mm)		0.51	108.65	4.438	1.21	0.049	106.10	4.334
Absorption: 30 % Batched Moisture Content: 0 %								
3. Poraver (0.5-1mm)		0.59	135.82	4.611	1.51	0.051	132.62	4.503
Absorption: 25 % Batched Moisture Content: 0 %								
4. Poraver (0.25-0.5mm)		0.71	118.43	3.208	1.32	0.036	115.65	3.132
Absorption: 20 % Batched Moisture Content: 0 %								
5. Emerson and Curing Ecospheres		0.27	45.63	2.709	0.51	0.030	44.56	2.645
Absorption, 0 % Batched Moisture Content: 0 %								
Total of All Aggregates			452.00	15.402	5.02	0.171	441.36	15.039
<b>Water</b>								
Batched Water		1.00	172.00	2.756	1.91	0.031	167.95	2.692
Total Free Water from All Aggregates		1.00	-90.24	-1.446	-1.00	-0.016	-88.11	-1.412
Total Water from All Admixtures		1.00	120.38	1.929	1.34	0.021	117.55	1.884
Total Water			202.14	3.239	2.25	0.036	197.39	3.163
<b>Admixtures</b>		% Solids	Amount (fl oz/cw t)	Water <sup>‡</sup> in Admixture (lb/yd <sup>3</sup> )	Amount (fl oz)	Water <sup>‡</sup> in Admixture (lb)	Amount (fl oz/cw t)	Water <sup>‡</sup> in Admixture (lb/yd <sup>3</sup> )
1. Daravair 1000 (AEA)		5.0	6.0	2.65	0.5	0.029	6.0	2.59
2. BASF Styrofan 1186 (Latex)		47.4	482.4	117.73	37.9	1.308	482.4	114.96
4. Pigment		100.0	0.0	0.00	0.0	0.000	0.0	0.00
Cement-Cementitious Materials Ratio				0.50		0.50		0.50
Water-Cementitious Materials Ratio				0.29		0.29		0.29
Flow (flow table), Slump, Slump Flow, in.				4.0		3.5		3.5
Air Content, %				10		14		12.41
Density (Unit Weight)**, lb/ft <sup>3</sup>				59.02		57.44		57.44
Gravimetric Air Content, %						12.41		
Yield**, ft <sup>3</sup>				27.00		0.31		27.00

\* For aggregates provide ASTM C 127 saturated, surface-dry bulk specific gravity.

‡ Water content of admixture.

\*\* Solid admixtures included in calculations

## Appendix B - Mixture Proportions

Mixture: Crimson Structural Mixture		SSD Proportions as Designed		Actual Batched Proportions		SSD Yielded Proportions		
Batch Size (ft <sup>3</sup> ): 0.3		Amount (lb/yd <sup>3</sup> )	Volume (ft <sup>3</sup> )	Amount (lb)	Volume (ft <sup>3</sup> )	Amount (lb/yd <sup>3</sup> )	Volume (ft <sup>3</sup> )	
<b>Cementitious Materials</b>		Specific* Gravity						
1. ASTM C150 Portland Cement Type: II	3.15	353.50	1.798	3.93	0.020	353.31	1.797	
2. Class C Fly Ash	2.58	106.05	0.659	1.18	0.007	105.99	0.658	
3. Slag Cement	3.00	176.75	0.944	1.96	0.010	176.66	0.944	
4. CTS Type-K Cement	3.10	70.70	0.365	0.79	0.004	70.66	0.365	
Total of All Cementitious Materials			707.00	3.767	0.042	706.63	3.765	
<b>Fibers</b>								
1. CTS K-Fiber™	2.7	36.00	0.214	0.40	0.002	35.98	0.214	
<b>Aggregates</b>								
1. Buildex Expanded Shale - <i>Marquette</i>								
Absorption: 10 %	1.6	43.27	0.433	0.48	0.005	43.25	0.433	
Batched Moisture Content: 10 %								
2. Poraver (1-2mm)								
Absorption: 30 %	0.51	108.17	4.419	1.20	0.049	108.12	4.416	
Batched Moisture Content: 0 %								
3. Poraver (0.5-1mm)								
Absorption: 25 %	0.59	135.22	4.591	1.50	0.051	135.14	4.589	
Batched Moisture Content: 0 %								
4. Poraver (0.25-0.5mm)								
Absorption: 20 %	0.71	117.91	3.194	1.31	0.035	117.85	3.192	
Batched Moisture Content: 0 %								
5. Emerson and Cuming Eccospheres								
Absorption, 0 %	0.27	45.43	2.697	0.50	0.030	45.41	2.695	
Batched Moisture Content: 0 %								
Total of All Aggregates			450.00	15.333	5.00	0.170	449.76	15.325
<b>Water</b>								
Batched Water	1.00	171.50	2.748	1.91	0.031	171.41	2.747	
Total Free Water from All Aggregates	1.00	-89.84	-1.440	-1.00	-0.016	-89.79	-1.439	
Total Water from All Admixtures	1.00	120.38	1.929	1.34	0.021	120.32	1.928	
Total Water			202.04	3.238	2.24	0.036	201.94	3.236
<b>Admixtures</b>		% Solids	Amount (fl oz/cw t)	Water <sup>‡</sup> in Admixture (lb/yd <sup>3</sup> )	Amount (fl oz)	Water <sup>‡</sup> in Admixture (lb)	Amount (fl oz/cw t)	Water <sup>‡</sup> in Admixture (lb/yd <sup>3</sup> )
1. Daravair 1000 (AEA)	5.0	6.0	2.65	0.5	0.029	6.0	2.65	
2. BASF Styrofan 1186 (Latex)	47.4	482.4	117.73	37.9	1.308	482.4	117.67	
4. Pigment	100.0	9.4	0.00	0.7	0.000	9.4	0.00	
Cement-Cementitious Materials Ratio			0.50	0.50		0.50		
Water-Cementitious Materials Ratio			0.29	0.29		0.29		
Flow (flow table), Slump, Slump Flow, in.			4.0	5.0		5.0		
Air Content, %			10	14		10.05		
Density (Unit Weight)**, lb/ft <sup>3</sup>			59.71	59.68		59.68		
Gravimetric Air Content, %				10.05				
Yield**, ft <sup>3</sup>			27.00	0.30		27.00		

\* For aggregates provide ASTM C 127 saturated, surface-dry bulk specific gravity.

‡ Water content of admixture.

\*\* Solid admixtures included in calculations

## Appendix B - Mixture Proportions

Mixture: Black Inlay Mixture		SSD Proportions as Designed		Actual Batched Proportions		SSD Yielded Proportions		
Batch Size (ft <sup>3</sup> ): 0.3		Amount (lb/yd <sup>3</sup> )	Volume (ft <sup>3</sup> )	Amount (lb)	Volume (ft <sup>3</sup> )	Amount (lb/yd <sup>3</sup> )	Volume (ft <sup>3</sup> )	
<b>Cementitious Materials</b>		Specific* Gravity						
1. ASTM C150 Portland Cement Type: II	3.15	424.20	2.158	4.71	0.024	426.33	2.169	
2. Class C Fly Ash	2.58	106.05	0.659	1.18	0.007	106.58	0.662	
3. Slag Cement	3.00	176.75	0.944	1.96	0.010	177.64	0.949	
4. CTS Type-K Cement	3.10	0.00	0.000	0.00	0.000	0.00	0.000	
Total of All Cementitious Materials			707.00	3.761	7.86	0.042	710.55	3.780
<b>Fibers</b>								
1. CTS K-Fiber™	2.7	24.00	0.142	0.27	0.002	24.12	0.143	
<b>Aggregates</b>								
1. Buildex Expanded Shale - <i>Marquette</i>	1.6	43.27	0.433	0.48	0.005	43.49	0.436	
Absorption: 10 %								
Batched Moisture Content: 10 %								
2. Poraver (1-2mm)	0.51	108.17	4.419	1.20	0.049	108.72	4.441	
Absorption: 30 %								
Batched Moisture Content: 0 %								
3. Poraver (0.5-1mm)	0.59	135.22	4.591	1.50	0.051	135.90	4.614	
Absorption: 25 %								
Batched Moisture Content: 0 %								
4. Poraver (0.25-0.5mm)	0.71	117.91	3.194	1.31	0.035	118.50	3.210	
Absorption: 20 %								
Batched Moisture Content: 0 %								
5. Emerson and Cuming Eccospheres	0.27	45.43	2.697	0.50	0.030	45.66	2.710	
Absorption, 0 %								
Batched Moisture Content: 0 %								
Total of All Aggregates			450.00	15.333	5.00	0.170	452.26	15.410
<b>Water</b>								
Batched Water		1.00	173.50	2.780	1.93	0.031	174.37	2.794
Total Free Water from All Aggregates		1.00	-89.84	-1.440	-1.00	-0.016	-90.29	-1.447
Total Water from All Admixtures		1.00	120.38	1.929	1.34	0.021	120.99	1.939
Total Water			204.04	3.270	2.27	0.036	205.07	3.286
<b>Admixtures</b>		% Solids	Amount (fl oz/cw t)	Water‡ in Admixture (lb/yd <sup>3</sup> )	Amount (fl oz)	Water‡ in Admixture (lb)	Amount (fl oz/cw t)	Water‡ in Admixture (lb/yd <sup>3</sup> )
1. Daravair 1000 (AEA)		5.0	6.0	2.65	0.5	0.029	6.0	2.67
2. BASF Styrofan 1186 (Latex)		47.4	482.4	117.73	37.9	1.308	482.4	118.32
4. Pigment		100.0	15.7	0.00	1.2	0.000	15.7	0.00
Cement-Cementitious Materials Ratio				0.60		0.60		0.60
Water-Cementitious Materials Ratio				0.29		0.29		0.29
Flow (flow table), Slump, Slump Flow, in.				6.0		7.0		7.0
Air Content, %				10		14		9.50
Density (Unit Weight)**, lb/ft <sup>3</sup>				59.87		60.20		60.20
Gravimetric Air Content, %						9.50		
Yield**, ft <sup>3</sup>				27.00		0.30		27.00

\* For aggregates provide ASTM C 127 saturated, surface-dry bulk specific gravity.

‡ Water content of admixture.

\*\* Solid admixtures included in calculations

## Appendix B - Mixture Proportions

Mixture: Cream Finishing Mixture		SSD Proportions as Designed		Actual Batched Proportions		SSD Yielded Proportions		
Batch Size (ft <sup>3</sup> ): 0.3		Amount (lb/yd <sup>3</sup> )	Volume (ft <sup>3</sup> )	Amount (lb)	Volume (ft <sup>3</sup> )	Amount (lb/yd <sup>3</sup> )	Volume (ft <sup>3</sup> )	
<b>Cementitious Materials</b>		Specific* Gravity						
1. White Portland Cement Type: I	3.15	424.20	2.158	4.71	0.024	419.31	2.133	
2. Class C Fly Ash	2.58	106.05	0.659	1.18	0.007	104.83	0.651	
3. Slag Cement	3.00	176.75	0.944	1.96	0.010	174.71	0.933	
4. CTS Type-K Cement	3.10	0.00	0.000	0.00	0.000	0.00	0.000	
Total of All Cementitious Materials		707.00	3.761	7.86	0.042	698.85	3.718	
<b>Fibers</b>								
1. CTS K-Fiber™	2.7	0.00	0.000	0.00	0.000	0.00	0.000	
<b>Aggregates</b>								
1. Buildex Expanded Shale - <i>Marquette</i>	1.6	43.46	0.435	0.48	0.005	42.96	0.430	
Absorption: 10 % Batched Moisture Content: 10 %								
2. Poraver (1-2mm)	0.51	108.65	4.438	1.21	0.049	107.40	4.387	
Absorption: 30 % Batched Moisture Content: 0 %								
3. Poraver (0.5-1mm)	0.59	135.82	4.611	1.51	0.051	134.25	4.558	
Absorption: 25 % Batched Moisture Content: 0 %								
4. Poraver (0.25-0.5mm)	0.71	118.43	3.208	1.32	0.036	117.07	3.171	
Absorption: 20 % Batched Moisture Content: 0 %								
5. Emerson and Cuming Eccospheres	0.27	45.63	2.709	0.51	0.030	45.11	2.677	
Absorption, 0 % Batched Moisture Content: 0 %								
Total of All Aggregates		452.00	15.402	5.02	0.171	446.79	15.224	
<b>Water</b>								
Batched Water	1.00	186.00	2.981	2.07	0.033	183.86	2.946	
Total Free Water from All Aggregates	1.00	-90.24	-1.446	-1.00	-0.016	-89.20	-1.429	
Total Water from All Admixtures	1.00	120.38	1.929	1.34	0.021	118.99	1.907	
Total Water		216.14	3.464	2.40	0.038	213.65	3.424	
<b>Admixtures</b>		% Solids	Amount (fl oz/cwt)	Water <sup>‡</sup> in Admixture (lb/yd <sup>3</sup> )	Amount (fl oz)	Water <sup>‡</sup> in Admixture (lb)	Amount (fl oz/cwt)	Water <sup>‡</sup> in Admixture (lb/yd <sup>3</sup> )
1. Daravair 1000 (AEA)	5.0	6.0	2.65	0.5	0.029	6.0	2.62	
2. BASF Styrofan 1186 (Latex)	47.4	482.4	117.73	37.9	1.308	482.4	116.37	
4. Pigment	100.0	0.0	0.00	0.0	0.000	0.0	0.00	
Cement-Cementitious Materials Ratio			0.60		0.60		0.60	
Water-Cementitious Materials Ratio			0.31		0.31		0.31	
Flow (flow table), Slump, Slump Flow, in.			10.0		9.5		9.5	
Air Content, %			10		14		11.17	
Density (Unit Weight)**, lb/ft <sup>3</sup>			58.20		57.44		57.44	
Gravimetric Air Content, %					11.17			
Yield**, ft <sup>3</sup>			27.00		0.30		27.00	

\* For aggregates provide ASTM C 127 saturated, surface-dry bulk specific gravity.

‡ Water content of admixture.

\*\* Solid admixtures included in calculations

## Appendix B - Mixture Proportions

Mixture: Crimson Finishing Mixture		SSD Proportions as Designed		Actual Batched Proportions		SSD Yielded Proportions		
Batch Size (ft <sup>3</sup> ): 0.3		Amount (lb/yd <sup>3</sup> )	Volume (ft <sup>3</sup> )	Amount (lb)	Volume (ft <sup>3</sup> )	Amount (lb/yd <sup>3</sup> )	Volume (ft <sup>3</sup> )	
<b>Cementitious Materials</b>		Specific* Gravity						
1. ASTM C150 Portland Cement Type: II	3.15	424.20	2.158	4.71	0.024	417.64	2.125	
2. Class C Fly Ash	2.58	106.05	0.659	1.18	0.007	104.41	0.649	
3. Slag Cement	3.00	176.75	0.944	1.96	0.010	174.02	0.930	
4. CTS Type-K Cement	3.10	0.00	0.000	0.00	0.000	0.00	0.000	
Total of All Cementitious Materials		707.00	3.761	7.86	0.042	696.07	3.703	
<b>Fibers</b>								
1. CTS K-Fiber™	2.7	0.00	0.000	0.00	0.000	0.00	0.000	
<b>Aggregates</b>								
1. Buildex Expanded Shale - <i>Marquette</i>	1.6	43.27	0.433	0.48	0.005	42.60	0.427	
Absorption: 10 %								
Batched Moisture Content: 10 %								
2. Poraver (1-2mm)	0.51	108.17	4.419	1.20	0.049	106.50	4.351	
Absorption: 30 %								
Batched Moisture Content: 0 %								
3. Poraver (0.5-1mm)	0.59	135.22	4.591	1.50	0.051	133.13	4.520	
Absorption: 25 %								
Batched Moisture Content: 0 %								
4. Poraver (0.25-0.5mm)	0.71	117.91	3.194	1.31	0.035	116.09	3.144	
Absorption: 20 %								
Batched Moisture Content: 0 %								
5. Emerson and Cuming Eccospheres	0.27	45.43	2.697	0.50	0.030	44.73	2.655	
Absorption, 0 %								
Batched Moisture Content: 0 %								
Total of All Aggregates		450.00	15.333	5.00	0.170	443.04	15.096	
<b>Water</b>								
Batched Water	1.00	181.00	2.901	2.01	0.032	178.20	2.856	
Total Free Water from All Aggregates	1.00	-89.84	-1.440	-1.00	-0.016	-88.45	-1.417	
Total Water from All Admixtures	1.00	120.38	1.929	1.34	0.021	118.52	1.899	
Total Water		211.54	3.390	2.35	0.038	208.27	3.338	
<b>Admixtures</b>		% Solids	Amount (fl oz/cwt)	Water‡ in Admixture (lb/yd <sup>3</sup> )	Amount (fl oz)	Water‡ in Admixture (lb)	Amount (fl oz/cwt)	Water‡ in Admixture (lb/yd <sup>3</sup> )
1. Daravair 1000 (AEA)	5.0	6.0	2.65	0.5	0.029	6.0	2.61	
2. BASF Styrofan 1186 (Latex)	47.4	482.4	117.73	37.9	1.308	482.4	115.91	
4. Pigment	100.0	18.9	0.00	1.5	0.000	18.9	0.00	
Cement-Cementitious Materials Ratio			0.60		0.60		0.60	
Water-Cementitious Materials Ratio			0.30		0.30		0.30	
Flow (flow table), Slump, Slump Flow, in.			10.0		9.0		9.0	
Air Content, %			10		13		11.57	
Density (Unit Weight)**, lb/ft <sup>3</sup>			59.52		58.65		58.65	
Gravimetric Air Content, %					11.57			
Yield**, ft <sup>3</sup>			27.00		0.30		27.00	

\* For aggregates provide ASTM C 127 saturated, surface-dry bulk specific gravity.

‡ Water content of admixture.

\*\* Solid admixtures included in calculations

Appendix C - Gradation Curves and Tables

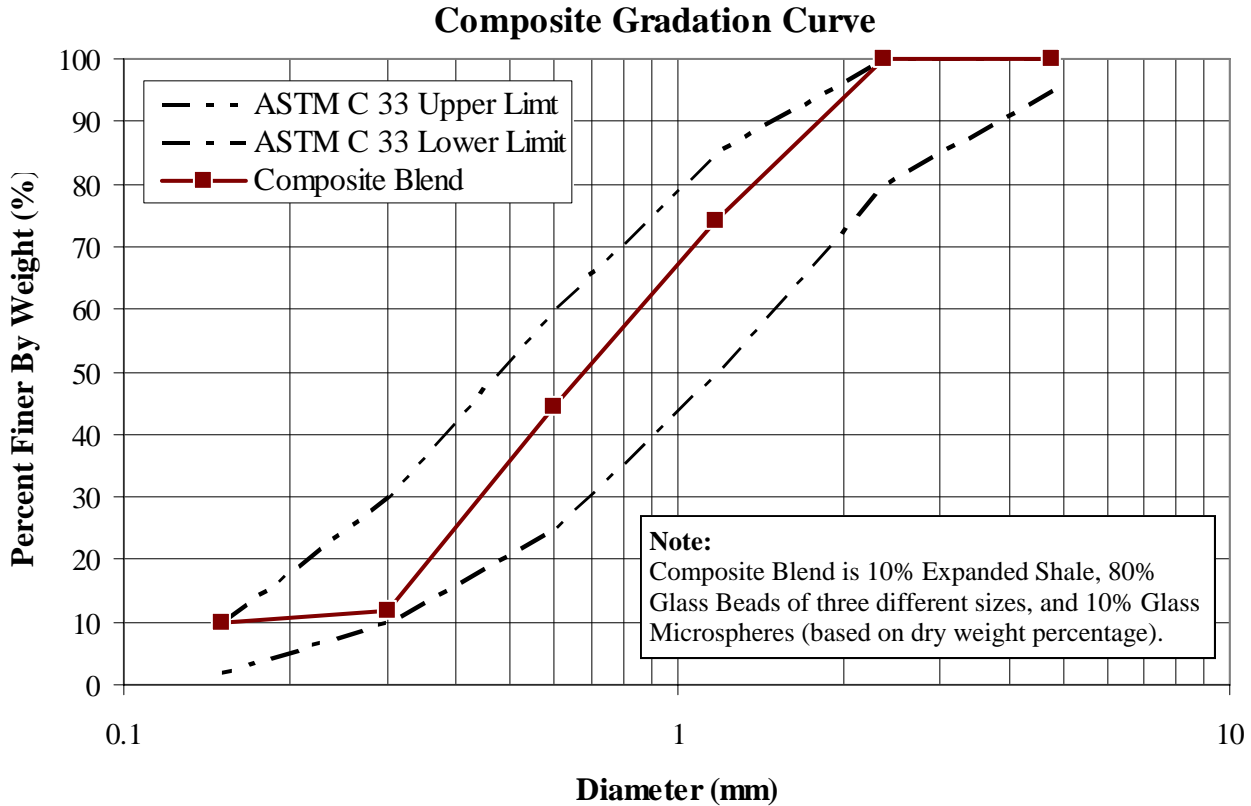

**Concrete Aggregate:** Composite Blend

**Sample Weight:** 416 grams

**Specific Gravity ( $G_s$ ):** 0.67

**Fineness Modulus:** 2.59

Sieve	Diameter (mm)	Weight Retained (g)	Cumulative Weight Retained (g)	Percent Finer (%)
#4	4.75	0	0	100.00
#8	2.36	0	0	100.00
#16	1.18	107	107	74.28
#30	0.6	124.25	231.25	44.41
#50	0.3	135.12	366.37	11.93
#100	0.15	8.05	374.42	10.00
Pan	0.01	41.58	416	0.00

Appendix C - Gradation Curves and Tables

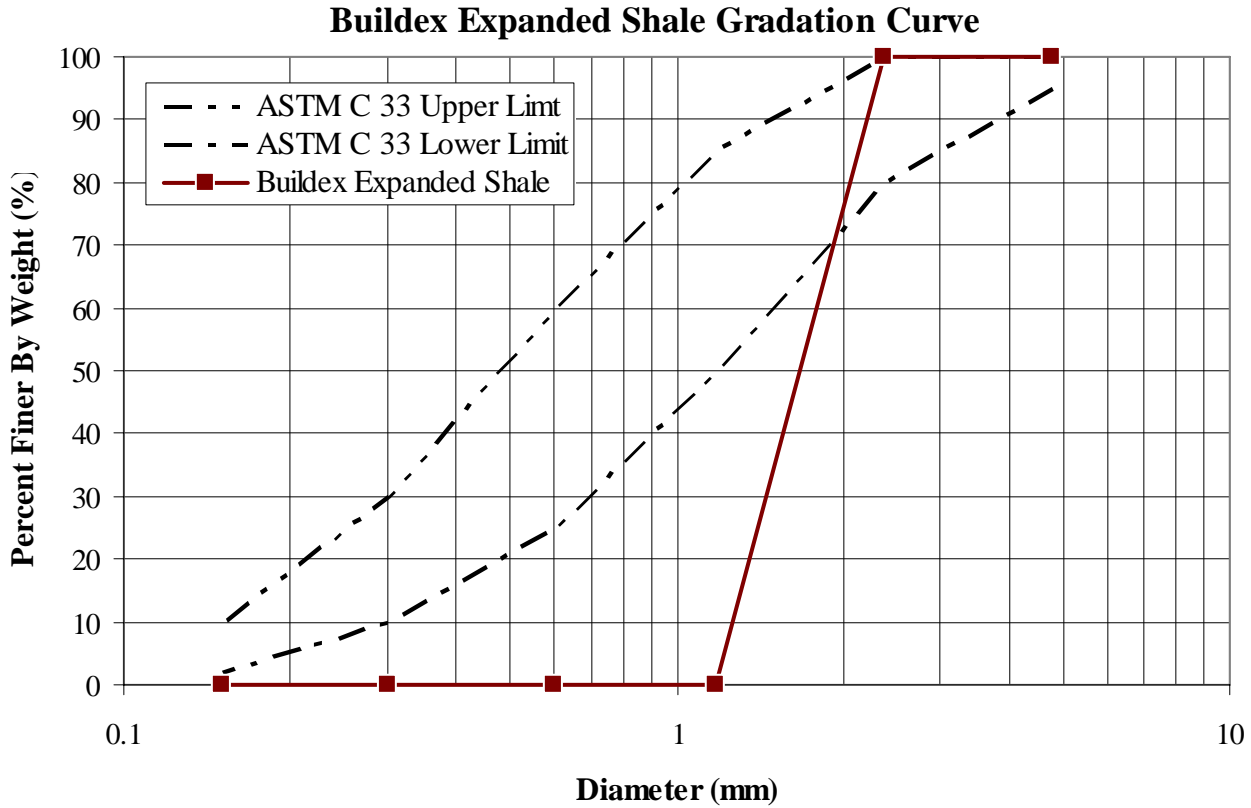

**Concrete Aggregate:** Buildex Expanded Shale

**Sample Weight:** 430 grams

**Specific Gravity ( $G_s$ ):** 1.6

**Fineness Modulus:** 4.00

Sieve	Diameter (mm)	Weight Retained (g)	Cumulative Weight Retained (g)	Percent Finer (%)
#4	4.75	0	0	100.00
#8	2.36	0	0	100.00
#16	1.18	430	430	0.00
#30	0.6	0	430	0.00
#50	0.3	0	430	0.00
#100	0.15	0	430	0.00
Pan	0.01	0	430	0.00

Appendix C - Gradation Curves and Tables

Poraver Glass Beads (1-2mm) Gradation Curve

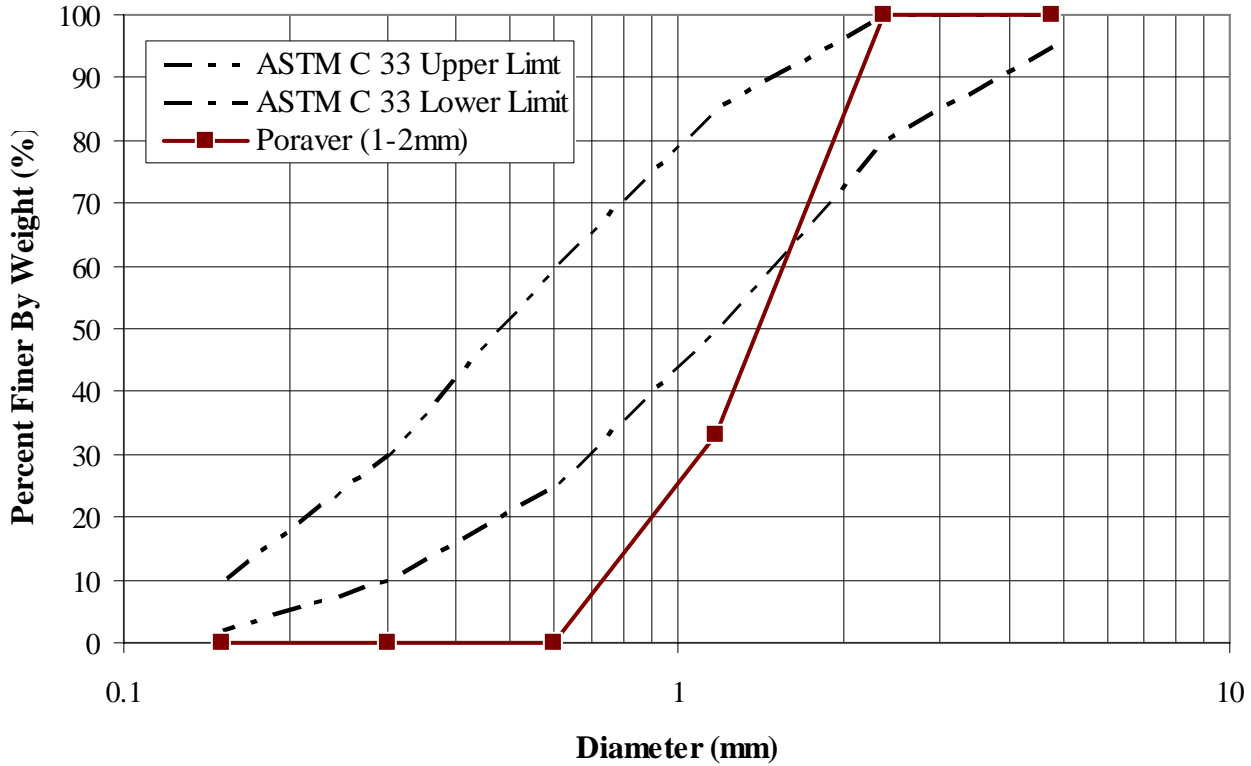

Concrete Aggregate: Poraver Glass Beads (1-2mm)

Sample Weight: 224 grams

Specific Gravity ( $G_s$ ): 0.51

Fineness Modulus: 3.67

Sieve	Diameter (mm)	Weight Retained (g)	Cumulative Weight Retained (g)	Percent Finer (%)
#4	4.75	0	0	100.00
#8	2.36	0	0	100.00
#16	1.18	150	150	33.04
#30	0.6	74	224	0.00
#50	0.3	0	224	0.00
#100	0.15	0	224	0.00
Pan	0.01	0	224	0.00

Appendix C - Gradation Curves and Tables

Poraver Glass Beads (0.5-1mm) Gradation Curve

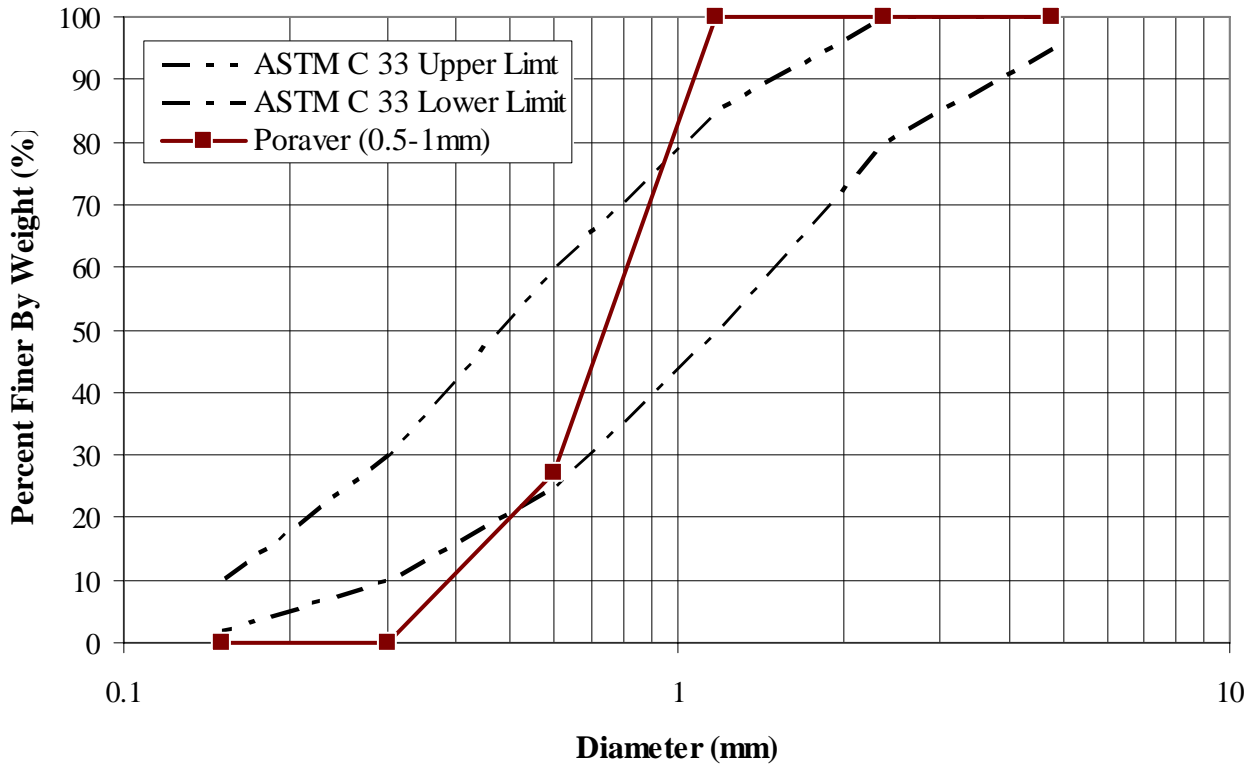

Concrete Aggregate: Poraver Glass Beads (0.5-1mm)

Sample Weight: 248 grams

Specific Gravity ( $G_s$ ): 0.59

Fineness Modulus: 2.73

Sieve	Diameter (mm)	Weight Retained (g)	Cumulative Weight Retained (g)	Percent Finer (%)
#4	4.75	0	0	100.00
#8	2.36	0	0	100.00
#16	1.18	0	0	100.00
#30	0.6	180	180	27.42
#50	0.3	68	248	0.00
#100	0.15	0	248	0.00
Pan	0.01	0	248	0.00

Appendix C - Gradation Curves and Tables

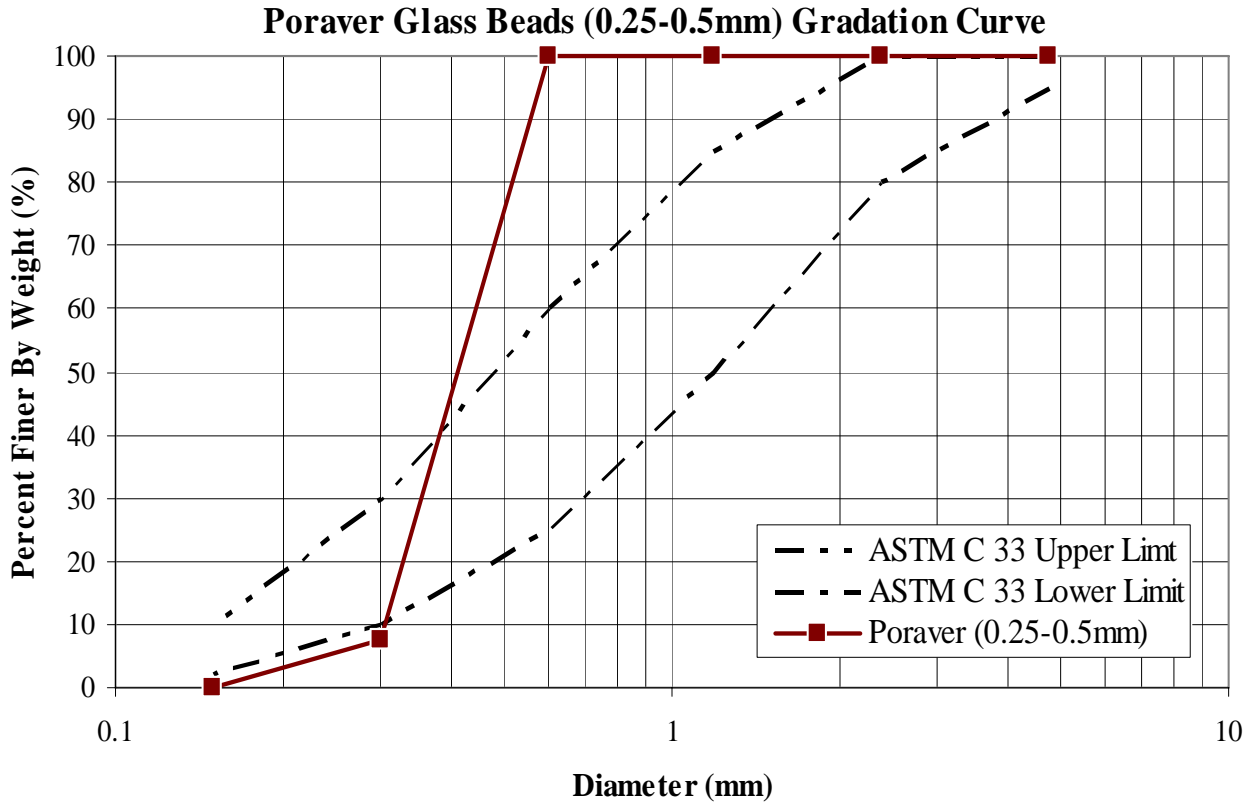

**Concrete Aggregate:** Poraver Glass Beads (0.25-0.5mm)

**Sample Weight:** 350 grams

**Specific Gravity ( $G_s$ ):** 0.71

**Fineness Modulus:** 1.93

Sieve	Diameter (mm)	Weight Retained (g)	Cumulative Weight Retained (g)	Percent Finer (%)
#4	4.75	0	0	100.00
#8	2.36	0	0	100.00
#16	1.18	0	0	100.00
#30	0.6	0	0	100.00
#50	0.3	324	324	7.43
#100	0.15	26	350	0.00
Pan	0.01	0	350	0.00

Appendix C - Gradation Curves and Tables

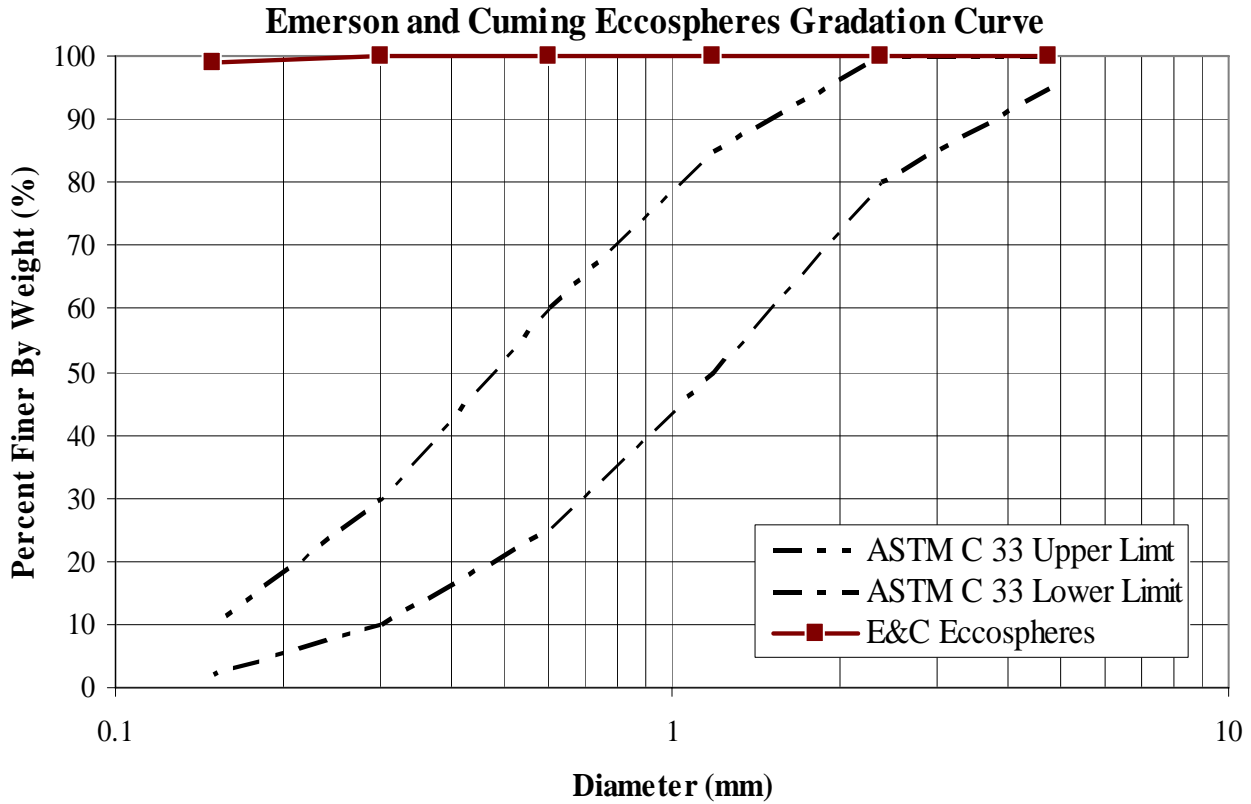

Concrete Aggregate: Emerson and Cuming Eccospheres

Sample Weight: 100 grams

Specific Gravity ( $G_s$ ): 0.27

Fineness Modulus: 0.01

Sieve	Diameter (mm)	Weight Retained (g)	Cumulative Weight Retained (g)	Percent Finer (%)
#4	4.75	0	0	100.00
#8	2.36	0	0	100.00
#16	1.18	0	0	100.00
#30	0.6	0	0	100.00
#50	0.3	0	0	100.00
#100	0.15	1	1	99.00
Pan	0.01	99	100	0.00